

## NHB Precision Balance

### General Specifications

- Display 16.5mm digit LCD display, with white LED backlight
- Capacities 150g~6000g
- Pan size  $\Phi 80\text{mm}$ ,  $\Phi 120\text{mm}$ , 140mm x 150mm
- Keyboard 7 keys (Membrane keyboard)
- Housing ABS plastic
- Max. Divisions 6,000e/60,000d/150,000d/300,000d
- ADC update  $\leq 1/10$  second
- Operating Temp.  $+5^{\circ}\text{C} \sim +40^{\circ}\text{C}$
- Power AC adapter (12V/500mA), Rechargeable battery (6V/1.2Ah)
- Gross weight 2.9kg (with wind shield), 2.7kg (without wind shield)



- Standard RS-232 interface
- OIML approval from DELTA (approval no.DK0199.424)
- Rechargeable battery provides up to 40 hours of continuous use (without backlight)
- Optional below bench weighing
- Optional USB communication port
- Optional rear display
- Optional bluetooth (4.3GHz, 10m)
- Applications: 1. Percentage weighing 2. Counting 3. Accumulation 4. Weighing unit conversion

## NHB Precision Balance

Model Nname	Capacity	Readability	Division	Pan Size	Approx. weight	Approval
NHB-600-M	600g	0.1g	6,000e	Φ 120mm	2.9kg	CE, OIML
NHB-6000-M	6000g	1g	6,000e	140 x 150mm	2.7kg	CE, OIML

### Options

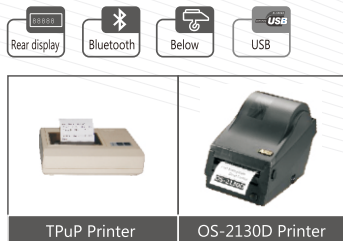

### Print formats

2012/03/07	13:38
PERCENT:	100.01%
2012/03/07	13:37
S/N0:	1
WEIGHT:	80.26 g
2012/03/07	13:37
S/N0:	1
TOTAL.WT:	80.26 g
2012/03/07	13:38
PCS:	222pcs
UNIT.WT:	0.40132 g
WEIGHT:	89.04 g

### Dimensions(mm)

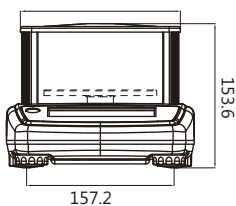
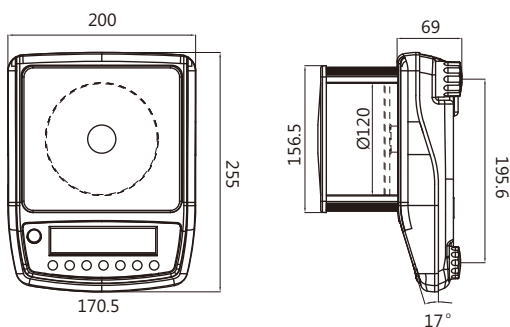

- Pan size
- Φ 80mm
  - Φ 120mm
  - 140x150mm

## VAAKATALO

**Vaakatalo Oy**  
**Vestonkatu 11**  
**33580 TAMPERE**  
**info@vaakatalo.com**  
**www.vaakatalo.com**